

A = GPL / LP gas / Gaz liquide / Flüssiggas
 B = Gas metano / Natural gas / Gaz naturel / Erdgas



N.B.: La tavola si completa con la successiva n° E01-042
 N.B.: See table No. E01-042
 N.B.: Voir tableau n° E01-042
 Wichtig: S. folgender Plan Nr. E01-042

E01-039

KFG4 - KFG8

Ed. 07/01

Rev. 1

Pezzi/Pieces Pieces/Anzahl					Pos.	Validità dalla matricola Validité du numéro matricule Validity from serial number Gültigkeit ab der (Seriennummer)	Validità alla matricola Validity up to serial number Validité au numéro matricule Gültigkeit bis zur (Seriennummer)	Codice Code Artikel Nummer	Descrizione	Description	Description	Beschreibung
			KFG4	KFG8								
			2	4	1			X23000	Bruciatore	Burner	Bruleur	Brenner
			1	2	2			X22900	Bruciatore con miccia	Burner + Connect. pipe	Bruleur avec raccord	Brenner mit Zünder
			3	6	3			X23500	Boccola registro aria	Air-regulation bush	Douille de réglage de l'air	Luftreglerbuchse
			3	6	4A			Y09300	Iniettore gas 120 GPL	LPG injector 120	Injecteur gaz 120 GPL	Gasdüse 120 GPL
			3	6	4B			Y09200	Iniettore gas 180 metano	Natural gas injector 180	Injecteur gaz 180 methane	Gasdüse 180 Methan
			1	2	5			X40500	Cavo A.T.L. 600	H.T. cable L. 600	Cable H.T.L. 600	Hochspannungsk. länge 600
			1	2	6			X16900	Candeletta	Ignition plug	Bougie	Glühkerze
			1	2	7			X19100	Termocoppia	Thermocouple	Thermocouple	Thermoelement
			1	2	8			X49000	Interruttore consenso	Consent Switch	Interrupteur habilitation	Entblockungsschalter
			1	1	9			X50000	Trasformatore A.T.	H.T. trasformer	Trasform. HT	Hochspann.Trasf.
			1	2	10			X50400	Bobina per valvola	Valve coil	Bobine pour valve	Spule für ventil
			1	1	11			X52400	Morsettiera	Terminal board	Barrette de raccordement	Klemmleiste
			1	2	12			0000X11400	Elettrovalvola	Electrovalve	Électovanne	Magnetventil
			1	2	13			1000X19000	Pilota completo	Complet pilot	Veilleuse complète	Zündflammenbrenner kompl.

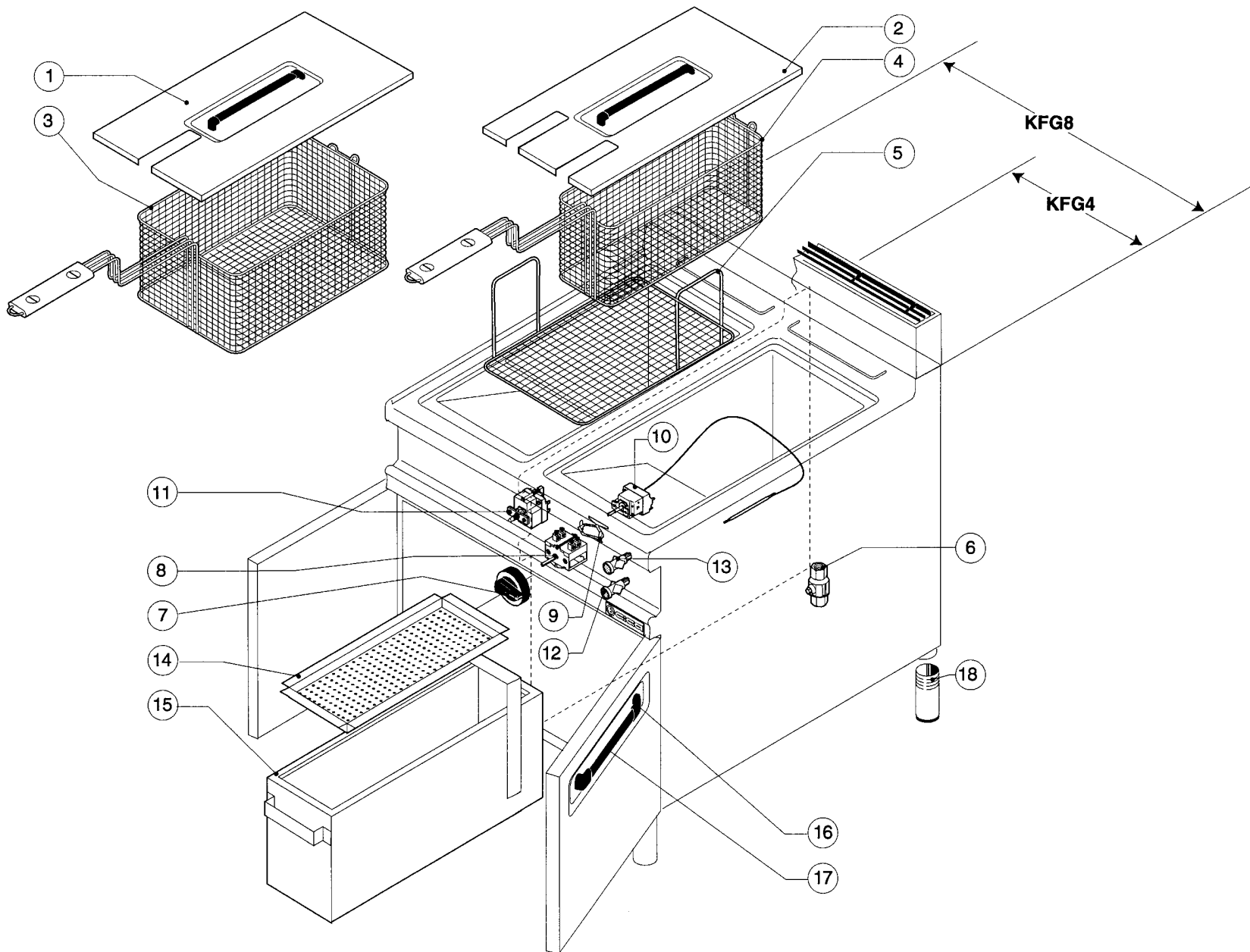

N.B.: La tavola si completa con la precedente n° E01-039
 N.B.: See table No. E01-039
 N.B.: Voir tableau n° E01-039
 Wichtig: S. vorstehender Plan Nr. E01-039

E01-042

KFG4 - KFG8

Ed. 07/01

Rev. 1

Pezzi/Pieces Pieces/Anzahl					Pos.	Validità dalla matricola Validité du numéro matricule Validity from serial number Gültigkeit ab der (Seriennummer)	Validità alla matricola Validity up to serial number Validité au numéro matricule Gültigkeit bis zur (Seriennummer)	Codice Code Artikel Nummer	Descrizione	Description	Description	Beschreibung
			KFG4	KFG8								
			1	2	1			0000K72000	Copricestello	Basket lid	Couvre-panier	Korbabdeckung
			1	2	2			0000K72100	Copricestello 2 tracce	Double basket lid	Couvre-panier à 2 découpes	Korbabd. Aussparungen
			1	2	3			Y46000	Cestello	Basket	Panier	Korb
			2	4	4			Y45900	Mezzocesto	Half basket	Demi-panier	Halbkorb
			1	2	5			Y46100	Retina filtro	Filter mesh	Grille filtre	Filternetz
			1	2	6			M75400	Rubinetto scarico	Outlet tap	Robinet vidange	Ablaufhahn
			1	2	7			0000Y04300	Manopola	Knob	Cle de commande	Drehknopf
			1	2	8			Y16200	Commutatore	Selector switch	Commutateur	Schalter
			1	2	9			X44600	Staffa per collegamento	Connecting bracket	Collier de raccordement	Anschlussbügel
			1	2	10			Y16000	Termostato mono 100/190	Mono thermostat 100/190	Thermostat mono 100/190	Mono-Thermostat10/190
			1	2	11			Y16300	Termostato di sicurezza	Safety thermostat	Thermostat de securite	Sicherheitsthermostat
			1	2	12			X41200	Lampada gialla	Yellow light	Lampe jaune	Gelbe Kontrollampe
			1	2	13			X50900	Lampada verde	Green light	Lampe vert	Grüne Kontrollampe
			1	2	14			B74900	Filtro raccogliolio	Oil filter	Filtre à huile	Fettauffangfilter
			1	2	15			B93900	Bacinella raccogliolio	Oil collecting tray	Bac récup. huile	Fettauffangbehälter
			4	8	16			Y03500	Supporto maniglia	Handle support	Support poignee	Griffträger
			2	4	17			M21100	Tubo maniglia	Handle pipe	Tube poignee	Griffhülse
			4	4	18			Y40400	Piedino	Foot	Pied	Fuss