

A = GPL / LP gas / Gaz liquide / Flüssiggas
 B = Gas metano / Natural gas / Gaz naturel / Erdgas



N.B.: La tavola si completa con la successiva n° E05-078
 N.B.: See table No. E05-078
 N.B.: Voir tableau n° E05-078
 Wichtig: S. folgender Plan Nr. E05-078

E05-075

CF15G4 - CF15DG8

Ed. 07/01

Rev. 1

Pezzi/Pieces Pieces/Anzahl					Pos.	Validità dalla matricola Validité du numéro matricule Validity from serial number Gültigkeit ab der (Seriennummer)	Validità alla matricola Validity up to serial number Validité au numéro matricule Gültigkeit bis zur (Seriennummer)	Codice Code Artikel Nummer	Descrizione	Description	Description	Beschreibung
			CF15G4	CF15DG8								
			2	4	1			X23000	Bruciatore	Burner	Bruleur	Brenner
			1	2	2			X22900	Bruciatore con miccia	Burner + Connect. pipe	Bruleur avec raccord	Brenner mit Zünder
			3	6	3			X23500	Boccola registro aria	Air-regulation bush	Douille de réglage de l'air	Luftreglerbuchse
			3	6	4A			X28100	Iniettore GPL	LPG injector	Injecteur GPL	Gasdüse GPL
			3	6	4B			X27900	Iniettore metano	Natural gas injector	Injecteur methane	Gasdüse Methan
			1	2	5			1000X19000	Pilota completo	Complet pilot	Veilleuse complète	Zündflammenbrenner Kompl.
			1	2	6			X16900	Candeletta	Ignition plug	Bougie	Glühkerze
			1	2	7			X19100	Termocoppia	Thermocouple	Thermocouple	Thermoelement
			1	2	8			X40500	Cavo A.T.L. 600	H.T. cable L. 600	Cable H.T.L. 600	Hochspannungsk. länge 600
			1	2	9			X50400	Bobina per valvola	Valve coil	Bobine pour valve	Spule für Ventil
			1	2	10			X49000	Interruttore consenso	Consent Switch	Interrupteur habilitation	Entblockungsschalter
			1	1	11			X50000	Trasformatore A.T.	H.T. transformer	Trasform. HT	Hochspann. Trasf.
			1	1	12			X52400	Morsettiera	Terminal board	Barrette de raccordement	Klemmleiste
			1	2	13			0000X11400	Elettrovalvola	Electrovalve	Électovanne	Magnetventil

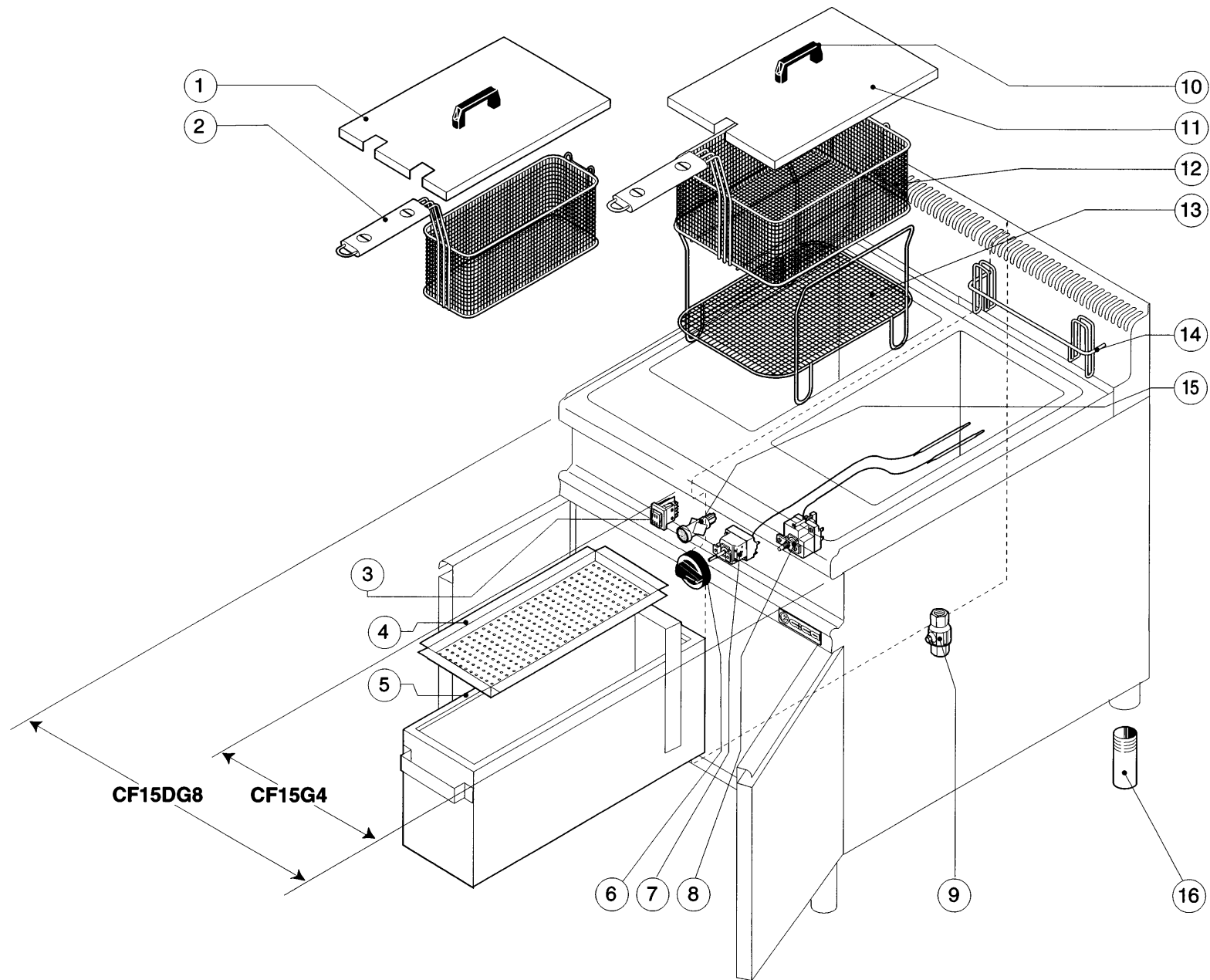

N.B.: La tavola si completa con la precedente n° E05-075
 N.B.: See table No. E05-075
 N.B.: Voir tableau n° E05-075
 Wichtig: S. vorstehender Plan Nr. E05-075

E05-078

CF15G4 - CF15DG8

Ed. 07/01

Rev. 1

Pezzi/Pieces Pieces/Anzahl					Pos.	Validità dalla matricola Validité du numéro matricule Validity from serial number Gültigkeit ab der (Seriennummer)	Validità alla matricola Validity up to serial number Validité au numéro matricule Gültigkeit bis zur (Seriennummer)	Codice Code Artikel Nummer	Descrizione	Description	Description	Beschreibung
			CF15G4	CF15DG8								
			1	2	1			0000B40700	Copricestello 2 tracce	Double basket lid	Couvre-panier à 2 découpes	Korbabd. Aussparungen
			2	4	2			X63200	Mezzocesto	Half basket	Demi-panier	Halbkorb
			1	1	3			X50800	Interruttore	Switch	Interrupteur	Hauptschalter
			1	2	4			B74900	Filtro raccogliolio	Oil filter	Filtre à huile	Fettauffangfilter
			1	2	5			B93900	Bacinella raccogliolio	Oil collecting tray	Bac récup. huile	Fettauffangbehälter
			1	2	6			0000X00700	Manopola	Knob	Cle de commande	Drehknopf
			1	2	7			Y16000	Termostato mono 100/190	Mono thermostat 100/190	Thermostat mono 100/190	Mono-Thermostat10/190
			1	2	8			Y16300	Termostato di sicurezza	Safety thermostat	Thermostat de securite	Sicherheitsthermostat
			1	2	9			M75400	Rubinetto scarico	Outlet tap	Robinet vidange	Ablaufhahn
			1	2	10			M20600	Maniglia	Handle	Poignee	Griff
			1	2	11			0000B94000	Copricestello	Basket lid	Couvre-panier	Korbabdeckung
			1	2	12			X64200	Cestello	Basket	Panier	Korb
			1	2	13			X64600	Retina filtro	Filter mesh	Grille filtre	Filternetz
			1	2	14			X63500	Gancio appendicesto	Basket hook	Crochet porte-panier	Korbaufhängehaken
			1	2	15			X41200	Lampada gialla	Yellow light	Lampe jaune	Gelbe Kontrollampe
			4	4	16			X61000	Piedino	Foot	Pied	Fuss